



L&C

LABELING
& CODING

EZ-100HSX HIGH SPEED TAMPER EVIDENT BAND APPLICATOR



Economical and flexible tamper band application at speeds up to 400cpm

The Axon EZ-100HSX tamper evident band applicator represents an excellent value for high speed operations. EZ-100HSX applicators are available with single-head and dual-head configurations. Dual-head models offer redundant production capacity which increase uptime during film reel changes or tamper band changeovers.

These fully automatic tamper evident band applicators utilize minimal moving parts for high reliability and low maintenance. As with all Axon machinery, the EZ-100HSX can be easily integrated with existing lines, or Axon can provide a complete system including the applicator, conveyor, and heat shrink tunnel.

FEATURES AND BENEFITS

- **Fully automatic** - Tamper evident band application process is fully automated and recipe driven and a touch screen HMI makes machine operation simple
- **Size range flexibility** - Container diameters or multipack cross-sections range from 1.38" (35 mm) to 2.83" (72 mm)
- **Simple to operate, easy to maintain** - Machine design minimizes use of moving parts which reduces complexity for both operators and maintenance personnel
- **Fast, tool-less size changeovers** - Size changeovers can be completed in five minutes or less
- **Guillotine style cutter** - Simple, durable and dependable two-blade cutting system delivers consistent, clean cuts with long blade life
- **Modular head design** - Single head applicator can be easily upgraded to a dual heads for increased production speeds
- **Cut-Push-Form System** - Tamper bands are cut and then pushed into a forming tube prior to application by the trailing tamper band. This approach enables steady state speeds up to 400 cpm

SHRINK APPLICATION



TAMPER EVIDENT



EZ-100HSX HIGH SPEED TAMPER EVIDENT BAND APPLICATOR

TYPICAL PRODUCT SPECIFICATIONS

Max. Rate (1 Head)	400 cpm*
Film Layflat Range	35 mm - 72 mm (1.38" - 2.83")
Closure Diameter	20 mm - 43 mm (.79" - 1.69")
Applied Materials	PVC, PETG, OPS, PLA

Film Thickness	50-70 microns (2.0-3.0 mil)
Power	220 VAC, 1-Phase
Air	3 cfm at 80 psi

* Dependent on product size and shape

CONFIGURATION

Top view

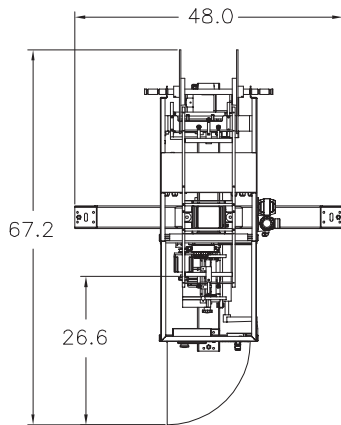

Front view

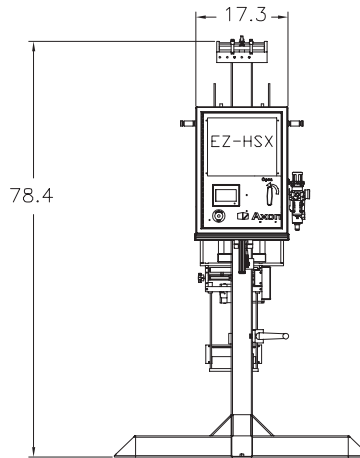

SHRINK APPLICATION



TAMPER EVIDENT

Dimensions are in inches

OPTIONS

- **Static Reduction** - Mitigates static build-up and increases uptime
- **Print Registration** - Fiber optic sensor reads film registration marks so the PLC can calculate cut lengths to assure sleeve length accuracy
- **Vertical Perforator** - Adds perforations to enhance ease of opening
- **Band Positioning** - Belt system assures correct placement of tamper bands during application process
- **Low Film Alarm** - Automatically detects low film levels and alerts operator
- **Product Spacers** - Precisely separate containers at the infeed to assure smooth production
- **Inspection Rejection System** - Detects high band, low band and no band
- **Infeed Timing Screws** - Required for multipacks and certain container geometries
- **Spare Parts Kit** - Recommended start-up parts inventory

©2019 ProMach Inc. ProMach reserves the right to change or discontinue specifications and designs shown in this brochure without notice or recourse
PM-AX-SP105_Axon_EZ-100HSX_0719v2

PHONE
919-772-8383

EMAIL
Axon@ProMachBuilt.com

WEB
AxonCorp.com

P.E. North America
3080 Business Park Dr, Suite 103
Raleigh, NC 27610